

## 1 Connect Battery

For safety, the Back-UPS ES is shipped with one battery wire disconnected. The UPS will not operate until the wire is connected to the touch-safe battery terminal. **NOTE:** Small sparks may occur during battery connection. This is normal.

- 1 Turn the Back-UPS ES over and press in the release tab. Slide the plastic battery cover off of the Back-UPS.
- 2 Connect the red battery wire firmly to the positive (+) battery terminal.
- 3 Insert the battery back into the compartment. Slide the plastic battery cover until the release tab locks into place.

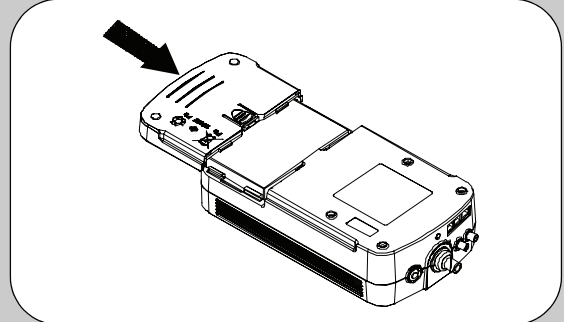
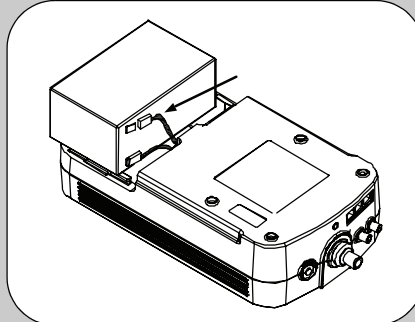
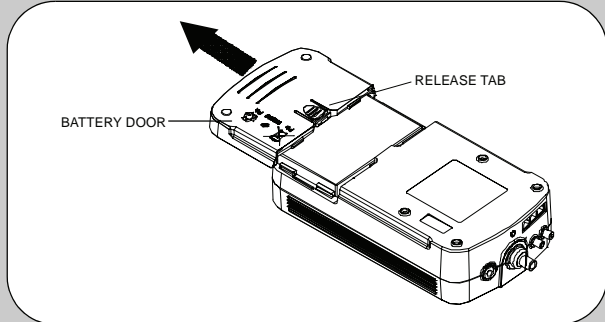

## 2 Connect Equipment

### Battery Back-up + Surge Protection

These outlets are powered whenever the Back-UPS ES is switched ON. During a power outage or other utility problems (brownouts, over-voltages), these outlets will be powered for a limited time by the Back-UPS ES. Plug your computer, monitor, CD-ROM drive and two other data-sensitive devices such as an external disk or tape drive, or Home Phoneline Networking Association (HPNA) device into these outlets.

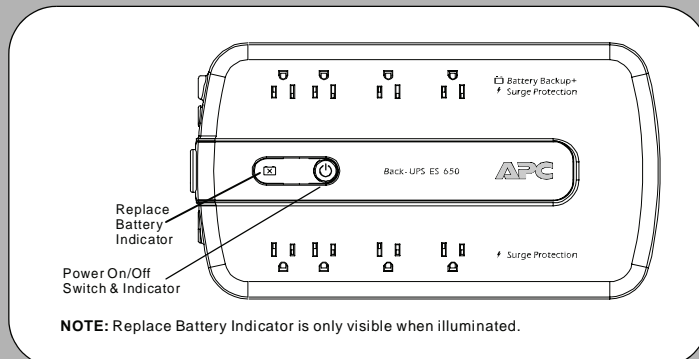

### Surge Protection

These outlets provide full-time protection from surges even if the Back-UPS ES is switched OFF. Plug your printer, fax machine, scanner, or other peripherals that do not need battery power into these outlets.

### Place the Back-UPS ES to avoid:

- Direct sunlight
- Excessive heat
- Excessive humidity or contact with fluids

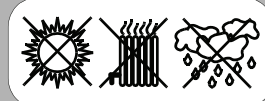

**Plug the Back-UPS ES power cord directly into a wall outlet; not into a surge protector or power strip.**

### Connect Computer Cable

The supplied cable and software provide automatic file saving and shutdown of the operating system in the case of a sustained power outage.

Connect the cable to the Data Port of the Back-UPS ES. Connect the other end of the cable to the USB port on your computer. The software will automatically find the computer's USB Port.

### Connect Modem / Phone / DSL / Fax / 10/100Base-T / HPNA / Cable Modem / CATV or DSS to Surge Protection

The Back-UPS protects a single line (2-wire) phone (including Digital Subscriber Line - DSL), Home Phoneline Networking Association (HPNA) type equipment, modem, 10/100 Base-T Ethernet, or fax machines from surges when connected through the UPS as shown in the drawing below.

The UPS also protects a cable modem, CATV converter, or DSS receiver from surges when it is connected through the UPS coaxial connectors as shown in the drawing below.

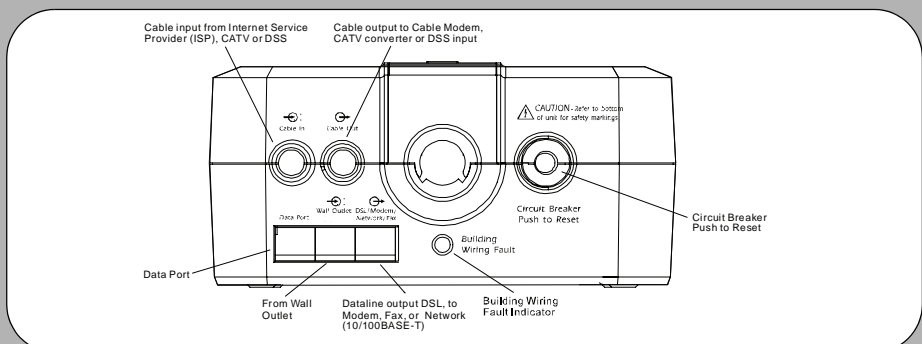

## 3 Power On and Install Software

**Press the ON/OFF switch to power the unit ON.**

A single short beep and the green "Power On" indicator confirms the Back-UPS ES is on and ready to provide protection.

The Back-UPS ES should charge for at least 16 hours to ensure sufficient runtime. The unit is being charged whenever it is connected to utility power, whether the unit is turned ON or OFF.

If the red Building Wiring Fault indicator (located on the end near the power cord) is lit, your building wiring presents a shock hazard that should be corrected by a qualified electrician.

### Install the PowerChute® Personal Edition software

Place the PowerChute Personal Edition CD-ROM into your computer and follow the installation instructions on the screen.

## Status Indicators

The Back-UPS ES indicates operating status using a combination of visual and audible indicators. Use the following table to identify the status of the Back-UPS ES.

Status	Visual Indications (Power On - Green) (Replace Battery - Red)	Audible Indication	Alarm Terminates When
<b>Power On</b> - UPS is supplying conditioned utility power to the load.	Power On pushbutton - ON (lit)	None	Not applicable.
<b>On Battery</b> - UPS is supplying battery power to the load connected to the Battery outlets.	Power On pushbutton - ON (off during beep)	Beeping 4 times every 30 seconds	UPS transfers back to Power On operation, or when UPS is turned off.
<b>Low Battery Warning</b> - UPS is supplying battery power to the load connected to the battery outlets, and the battery is near exhaustion.	Replace Battery indicator is flashing	Rapid beeping (every 1/2 second)	UPS transfers back to normal operation, or when UPS is turned off.
<b>Replace Battery</b> - The battery is disconnected.	Replace Battery indicator is Flashing	Constant tone	UPS is turned off with the power switch.
The battery is in need of charging, or is at the end of its usual life and must be replaced.	Power On and Replace Battery indicators - flashing (alternating)	Constant tone	
<b>Overload Shutdown</b> - During On Battery operation a battery power supplied outlet overload was detected.	None	Constant tone	UPS is turned off with the power switch.
<b>Sleep Mode</b> - During On Battery operation the battery power has been completely exhausted and the UPS is waiting for utility power to return to normal.	None	Beeping once every 4 seconds	Utility power is restored, or if utility power is not restored within 32 seconds, or the UPS is turned off.
<b>Building Wiring Fault</b> - Your building wiring presents a shock hazard that should be corrected by a licensed electrician.	Building Wiring Fault LED (red) - ON	None	UPS is unplugged, or UPS is plugged into a properly wired outlet.

See the Troubleshooting section for additional assistance.

# Troubleshooting

Use the table below to solve minor Back-UPS ES installation or operation problems. Consult APC Online Technical Support or call APC Technical Support for assistance with problems that cannot be resolved using the table below:

Problem	Probable Cause	Solution
Back-UPS ES will not turn on.	The battery is disconnected, and either power is unavailable at the wall outlet, or utility power is having a "brownout" or an "over voltage" condition.	Connect the battery (see <i>Connect Battery</i> ) and ensure power is available at the wall outlet. If battery is connected and power is unavailable, the unit can be "cold started" (operated on battery power) by holding the power button down until two beeps are heard.
No power available at the Surge Protection outlets.	Surge Protection outlets were overloaded.  Utility power not available at the wall outlet.	Reduce the amount of equipment plugged into the Surge Protection outlets.  Ensure the fuse or circuit breaker for the outlet is not tripped, and that the wall switch controlling the outlet (if any) is in the ON position.
Back-UPS is on, but Replace Battery indicator flashes, and unit emits a constant tone.	Battery is disconnected.	Connect the battery (see <i>Connect Battery</i> diagram).
Connected equipment loses power.	Equipment is connected to the "Surge Protection" outlets.  The Back-UPS ES is overloaded.  PowerChute Personal Edition software has performed a shutdown due to a power failure.  The Back-UPS ES has exhausted its available battery power.  Connected equipment does not accept the step-approximated sine waveform from the Back-UPS ES.  The Back-UPS ES may require service.	Ensure the equipment you want to stay powered during a power failure is plugged into the "Battery Backup plus Surge Protection" outlets and NOT the "Surge Protection Only" outlets.  Make sure the equipment plugged into the outlets of the unit are not overloading its capacity. Try removing some of the equipment and see if the problem continues.  The Back-UPS ES is operating normally.  The Back-UPS ES can only operate on battery power for a limited amount of time. The unit will eventually turn off when the available battery power has been used. Allow the unit to recharge for 16 hours before expecting maximum runtime.  The output waveform is designed for computers and computer-related equipment. It is not designed for use with motor-type equipment.  Contact APC Technical Support for further troubleshooting.
The Power On indicator is lit and the Back-UPS ES beeps four times every 30 seconds.	The Back-UPS ES is On Battery.	The Back-UPS ES is operating normally, and using battery power. Once On Battery, you may want to save your current work, power down your equipment, and turn the unit OFF. Once normal power is restored, you may turn the unit back ON, and power your equipment.
The Power On indicator flashes and the Back-UPS beeps twice per second at the same time.	Battery capacity is low (about 2 minutes of use remaining).	The Back-UPS ES is about to shut off due to a low battery charge condition! When the unit beeps twice every second, the battery has about 2 minutes of power remaining. Immediately power down your computer, and turn the unit OFF. When normal power returns, the unit will recharge the battery.
Building Wiring Fault indicator is lit.	Your building wiring presents a shock hazard. Using the Back-UPS with this condition will void the warranty.	Call a qualified electrician for service.
Inadequate runtime.	The battery is not fully charged.  Battery is near the end of useful life.	Allow the unit to charge by leaving it plugged into the wall at least 16 hours.  As a battery ages, the amount of runtime available will decrease. You can replace the battery by ordering one at <a href="http://www.apc.com">www.apc.com</a> . Batteries also age prematurely if the Back-UPS ES is placed near excessive heat.
No phone/fax/DSL/cable or network signal from the Back-UPS.	Data line from the ISP or wall outlet is connected to the wrong jack on the Back-UPS.	Make sure the data line from the wall outlet is connected to the jack labeled "Wall Outlet", or "Cable In" (Cable/DSS/CATV).
Internet connection lost during power outage.	Modem lost AC power.	Plug the modem's AC power cord into one of the "Battery Back-up Plus Surge Protection outlets".

## Specifications

Model	BE650G	
Input	Voltage	120 Vrms nominal
	Frequency	50 - 60 Hz (auto-sensing)
	Brownout Transfer	88 Vrms, typical
	Over-voltage Transfer	139 Vrms, typical
	Output	UPS Capacity (4 outlets)
	Total Amperage (8 outlets)	12 Amps (including UPS output)
	Voltage - On Battery	115 Vrms $\pm$ 8% (step-approximated sine wave)
	Frequency - On Battery	50 - 60 Hz $\pm$ 1 Hz
	Transfer Time	6 ms typical, 10 ms maximum
	Protection and Filter	AC Surge Protection
Phone/fax/DSL Surge Protection		Single line (2-wire)
Cable/CATV/DSS Surge Protection		One Coax Input/Output
Network Surge Protection		10/100Base-T Ethernet
EMI/RFI Filter		Full time
	AC Input	Resettable circuit breaker
	Battery	Type
	Average Life	3 - 5 years depending on the number of discharge cycles and environmental temperature
Physical	Net Weight	14.3 lb. (6.5 Kg.)
	Size	3.54" (H) x 12.6" (W) x 6.97" (D) (9.0 x 32.0 x 17.7 cm)
	Operating Temperature	+32°F to 104°F (0°C to 40°C)
	Storage Temperature	+5°F to 113°F (-15°C to 45°C)
	Operating Relative Humidity	0 to 95% non-condensing
	Operating Elevation	0 to 10,000 ft (0 to 3,000m)
	Safety and Regulatory	Safety Approvals
	EMC Compliance	<b>Notice:</b> This device complies with part 68 and part 15 of the FCC rules. Operation is subject to the following two conditions: (1) This device may not cause harmful interference, and (2) This device must accept any interference received, including interference that may cause undesired operation.  "On the bottom of this equipment is a label that contains, among other information, the FCC registration number and ringer equivalence number (REN) for this equipment. If requested, this information must be provided to the telephone company."

## Order Replacement Battery

Replace with an APC qualified battery. Replacement batteries can be ordered from [www.apc.com](http://www.apc.com) (valid credit card required). The replacement battery part number for this Back-UPS is: **RBC17**.

## Warranty

The standard warranty is 3 years from the date of purchase. APC's standard procedure is to replace the original unit with a factory reconditioned unit. Customers who must have the original unit back due to assigned asset tags and set depreciation schedules must declare such a need at first contact with APC Technical Support. APC will ship the replacement unit once the defective unit is received by the repair department or cross-ship upon the provision of a valid credit card number. The customer pays for shipping to APC, and APC pays ground freight transportation costs back to the customer.

## Service

Please DO NOT RETURN Back-UPS ES to the place of purchase under any circumstances.

- Consult the Troubleshooting section to eliminate common problems.
  - Verify the battery is connected (see *Connect Battery*) and that the Circuit Breaker is not tripped (see *Troubleshooting* section).
- If you still have problems or questions, please contact APC via the internet or at one of the phone numbers listed below.
- Before contacting APC, please be sure to record the date purchased, UPS model, and serial number (on bottom of unit).
  - Be prepared to troubleshoot the problem over the telephone with a Technical Support Representative. If this is not successful, the representative will issue a Return Material Authorization Number (RMA#) and a shipping address.
  - Pack the unit in its original packaging. If the original packaging is not available, ask APC Technical Support about obtaining a new set. Pack the unit properly to avoid damage in transit. Never use foam beads for packaging. Damage sustained in transit is not covered under warranty (insuring the package for full value is recommended).
  - Write the RMA# on the outside of the package.
  - Return the unit by insured carrier to the address given to you by APC Technical Support.

## APC Contact Information

Online Technical Support:	<a href="http://support.apc.com">http://support.apc.com</a> <a href="http://www.apc.com/support">http://www.apc.com/support</a> <a href="mailto:esupport@apcc.com">esupport@apcc.com</a>
Web Site:	<a href="http://www.apc.com">www.apc.com</a>
USA/Canada:	1.800.800.4272
Mexico:	+52.292.0253 / 52.292.0255
Brazil:	+0800.12.72.1
Worldwide:	+1.401.789.5735